

OIL SAMPLING PROCEDURE

To enable efficient and accurate analysis the following information needs to be provided with the oil sample, If possible on the label.

1. Company name.
2. Equipment Name.
3. Oil Type. (Gearbox, hydraulic, diesel engine petrol engine etc.)
4. Oil Make & Grade (Shell Omala 220 etc.)
5. Oil Sampling Point.
6. Running hours.
7. Running hours since last oil change if known.
8. Any known problems.

IMPORTANT - To ensure the sample is representative

1. Always sample well-mixed oil after running at least 15 minutes.
2. Always sample oil at normal operating temperatures.
3. **DO NOT** allow external dirt to enter the sample.
4. When sampling from the drain ensure the oil is hot.
5. Check remaining oil level and top up as required

When sampling from drain (not preferable)

1. **DO NOT** take the sample as the oil starts to drain.
2. **DO NOT** take the sample as the oil finishes draining.
3. Take the sample directly into the bottle after the oil has been draining for a short period.
4. **DO NOT** take the sample from oil collected in another container.
5. Check remaining oil level and top up as required

1. Install the sample bottle on the suction pump.
2. Insert pump hose into the dipstick tube to the same depth as the dipstick or into the storage tank sufficient to reach the centre of the fluid store.
3. Operate the pump until the bottle is at least 1/3 full. (**Full bottle for Hydraulic oils**)
4. Forward the sample to the lab.
5. Discard the hose correctly on completion of sampling. **Do not re use.**
6. To avoid contaminating the pump **do not** operate it on its side or overfill sample bottles.

With Syringe

1. Connect sufficient length of hose to the syringe to reach the centre of the fluid store
2. Insert the hose into the dipstick tube to the same depth as the dipstick or into the storage tank sufficient to reach the centre of the fluid store.
3. Withdraw the syringe plunger to obtain a sample. Detach the syringe from the tube and empty into the sample bottle. Repeat this process until the sample bottle is at least 1/3 full. (**Full bottle for Hydraulic oils**) Forward this sample to the lab.
4. Discard hose and syringe correctly on completion of sampling. **Do not re use.**

With oil pressure line sampling valve

1. A suitable drain valve can be connected to a "T" in an oil pressure line. The discharge side of the valve should be fitted with a pipe plug or cap.
2. Before taking an oil sample a small amount of oil should be run off in order to eliminate any residual contamination in the oil lines.
3. Ensure the sample bottle is at least 1/3 full. (**Full bottle for Hydraulic oils**)
4. Forward this sample to the lab.

IMPORTANT

Always ensure that used hose, syringes, disposable gloves and cloths are disposed of as per site regulations.

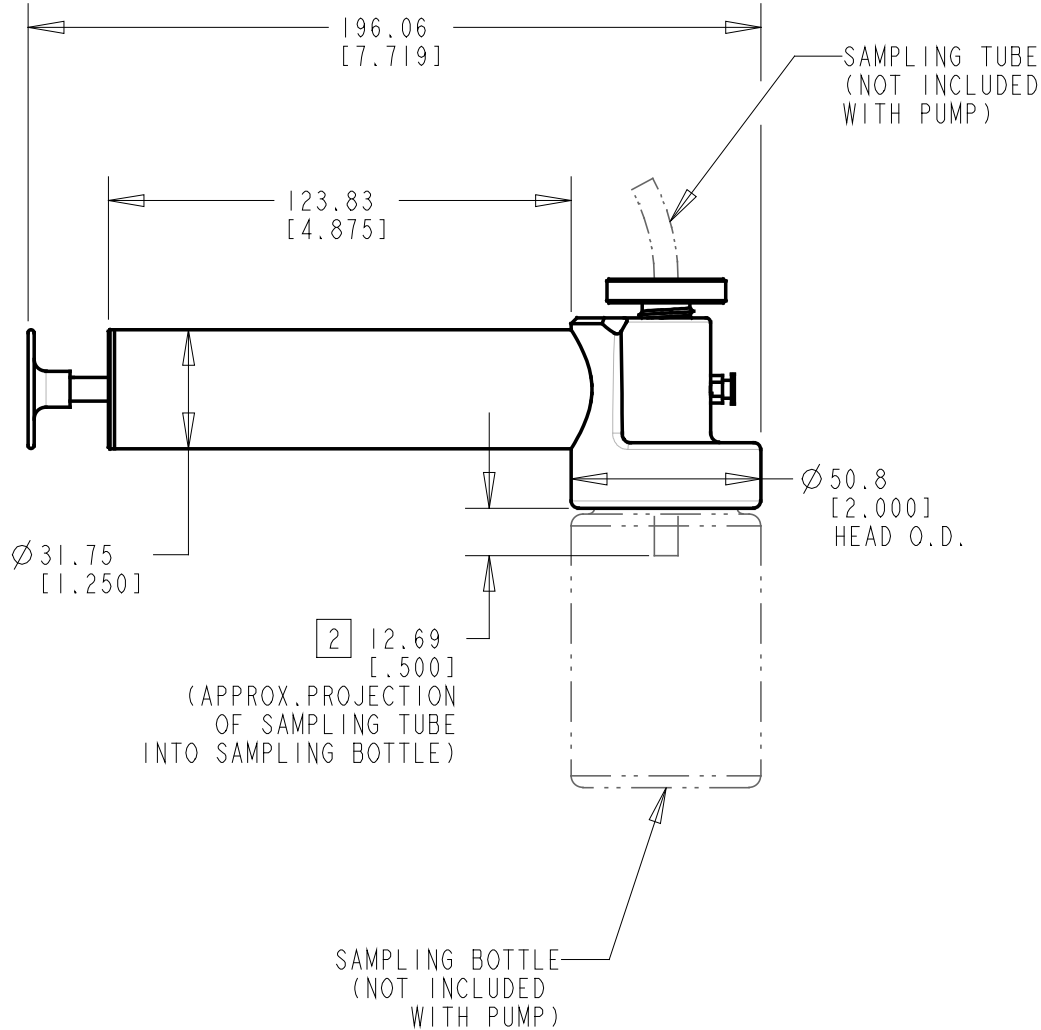

NOTES:

1. SAMPLING TUBE O.D. SIZES - WITHOUT ANY CHANGE OF FITTINGS, THIS PUMP WILL ACCEPT THE FOLLOWING TUBE SIZES:

- 5/16" [7.9375 MM]
- 1/4" [6.35 MM]
- 3/16" [4.7625 MM]

TO AVOID CROSS CONTAMINATION OF SAMPLES, USE A NEW TUBE FOR EVERY SAMPLE.

2. WHEN PREPARING TO DRAW AN OIL SAMPLE, ALWAYS INSERT THE SAMPLING TUBE COMPLETELY THROUGH THE COUPLING DEVICE, WITH THE END OF THE TUBE PROJECTING ABOUT 1/2" [12.69 MM] BELOW THE TOP OF THE SAMPLE CONTAINER. THE FLUID BEING SAMPLED WILL THEN FLOW FROM THE TUBE DIRECTLY INTO THE CONTAINER WITHOUT COMING IN CONTACT WITH ANY PART OF THE PUMP. THIS NOT ONLY PREVENTS CROSS CONTAMINATION OF SAMPLES, BUT (WITH A LITTLE CARE) ALLOWS AN UNLIMITED NUMBER OF SAMPLES TO BE DRAWN WITHOUT THE NECESSITY OF CLEANING THE PUMP.
3. CUTTING THE ENDS OF THE SAMPLING TUBE TO AN ANGLE OF APPROXIMATELY 45° WILL HELP PREVENT SCRAPING UP OF SLUDGE FROM THE INSIDE OF DIP STICK PIPES AND/OR SIDES AND BOTTOM OF OIL RESERVIORS WHEN INSERTING SAMPLING TUBES
4. TO COMMENCE DRAWING AN OIL SAMPLE, BE SURE INLET END OF SAMPLE TUBE IS WELL BELOW THE SURFACE OF THE FLUID TO BE SAMPLED, THEN BEGIN PUMPING. THE PUMP SHOULD DRAW 27 IN. HG. VACUUM IN EIGHT OR NINE STROKES. WATCH CLOSELY AS THE FLUID STARTS FLOWING; WHEN THE BOTTLE IS ABOUT 3/4 FULL, EITHER PUSH THE VACUUM RELEASE VALVE (XV MODEL) OR LOOSEN THE COUPLING DEVICE KNOB TO STOP THE FLOW. HOLDING IT IN WILL ALLOW THE TUBE TO DRAIN.
5. TO REMOVE HEAD FOR CLEANING OR REPAIRS, GRASP BARREL IN ONE HAND AND TAP HEAD LIGHTLY WITH SMALL MALLET.

VAMPIRE FLUID SAMPLING PUMP
MODELS X AND XV

DRAWING UNITS: MM/INCH

SHEET 1 OF 2